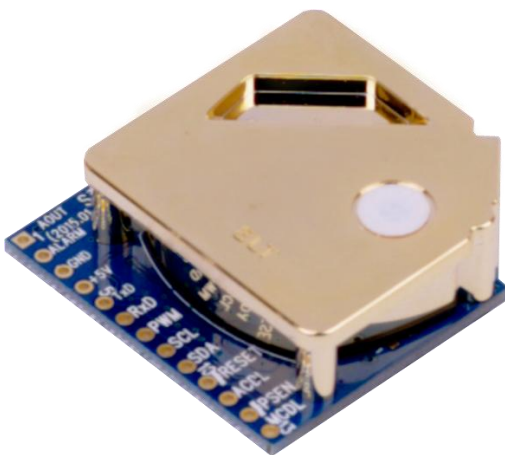

General

Version 1.23

S-300 is one of smallest CO₂ sensor modules in the world. Its Persistent Stability and Temperature Effect Resistance besides easy management are much favored by customers in stocks raising, greenhouse, scientific projects, etc. S-300-3V is much favored by customers whose application needs 3.3Voltage input and sleep mode support so on.

ELT Sensor Data Sheet for S-300-3V

**Features**

- Non-Dispersive Infrared (NDIR) technology used to measure CO₂ levels.
- Pre-calibrated
- Available outputs : TTL-UART, I2C, Alarm (PWM/AVO option)
- Gold-plated sensor provides long-term calibration stability.
- Installed re-calibration function
- Periodic Automatic Calibration (ACDL) and Non-Periodic Manual Re-Calibration (MCDL) are available.
- ROHS Directive- 2011/65/EU, [EN50581 : 2012, IEC 62321-3-1 : 2013].
- Size : 33mmx33mmx13.1mm
- Weight : 10 grams

S-300-3V Specifications

General Performance

Operating Temperature : -10 ~ 60°C

Operating Humidity : 0 ~ 95% RH (Non-condensing) , 'G' option : 0 ~ 99% RH (Non-condensing)

Operating Environment : Residential, Commercial spaces

Storage Temperature : -30°C ~70°C

CO₂ Measurement

Sensing Method : NDIR (Non-dispersive Infrared)

Measurement Range : 0 ~ 2,000 (0~3,000/5,000/10,000ppm, 2%/3%/5% models are available)

Accuracy : ±30ppm ±3% of reading ⁽¹⁾⁽²⁾⁽³⁾ (±300ppm ±3% of reading - 2%/3%/5% models)

Step Response Time (1/e) : 60 seconds

Sampling Interval: 3 seconds

Warming-up Time : < 6 seconds (for Operation), 5 minutes (for Accuracy)

Electrical Data

Power Input : 3.2V ~ 3.6V ⁽⁴⁾

Current Consumption : Normal mode : 12mA, Peak < 180mA , Sleep < 0.3mA

Product Derivatives and Relative Functions

Products	Option List
S-300-3V	UART,I2C, ALARM. (AVO or PWM is option), 10'MCDL, ACDL,13+14 Connector
S-300L-3V	Sleep mode is added on S-300, which consume < 0.3mA
S-300G-3V	Resistance up to 99% Humidity for Application of Green House
S-300LG-3V	Sleep mode + 99% Humidity
S-300A-3V (ACDL S/W)	ACDL Software is added on S-300, which Calibrate Sensor every week

S-300-3V has various output TTL-UART, I2C and ALARM while as PWM / AVO is selectable as option). 2.54pitch 13pin side hole connector besides 2mm pitch 10 and 4pin 2 row header connectors.

(1)Accuracy of ±20ppm ±3% is acquirable through ACDL logic after 3 times 3 weeks

(2) or 10 minutes MCDL with Standard CO2 gas can be used as option..

(3) Air pressure is assumed as 101.3 kPa

(4) DC Supply should be regulated , low noise power source for best accuracy

Periodic Automatic Calibration (ACDL) and Non-Periodic Manual Calibration (10' MCDL) are executable by sending 'Low Signal' to pin-11 and pin-13.

There are 3 derivatives which has additional function on S-300-3V, S-300L-3V is Low Power model, consumes 0.3 mA in Sleep mode while as S-300G-3V is hardware-enforced one to be resistant up to 99% humidity for customers whose application is Greenhouse and Stock Raising, so on.

S-300A-3V has ACDL software and calibrate weekly after once in 2day from power-on, without 'Low signal' to J12-7 and J13-13 during operation, appropriate for Indoor Air-Quality Monitoring.

Pin Map with J11&J12 Connectors

J-11	Description	
1/3	VDD (+3.3V VCC)	
2/4	GND	

J-12	S-300-3V	S-300-3V (Analog Option)
1	TTL RXD (← CPU of Master Board)	
2	TTL TXD (→ CPU of Master Board)	
3	I2C SCL	
4	I2C SDA	
5	GND	
6	Reserved	Analog Voltage Output (0.5~3V) option
7	ACDL(Automatic Calibration)	
8	Reserved	
9	MCDL(10 min. Manual Calibration)	
10	Reset (Low Active)	

UART (J-12:P1&P2) : 38,400BPS, 8bit, No parity, 1 stop bit

I2C (J-12:P3&P4) : Slave mode only, Internal pull up resistor (10kΩ)
 TTL Level Voltage : $0 \leq V_{IL} \leq 0.4, 2 \leq V_{IH} \leq V_{DD}, 0 \leq V_{OL} \leq 0.4, 2.4 \leq V_{OH} \leq V_{DD}$ (Volt)

ALARM (Open Collector type)

1,000 ppm ≤ Alarm ON, 800 ppm ≥ Alarm OFF and alarming range can be change by EK-100SL with connected to PC.

Option 1 : Analog Voltage(J-12:pin-6, J-13:pin-1) : 0.5~3.0 V.

Option 2 : PWM (J-13:pin-7 is available) In case the PWM option is chosen,

$$t_H = 2 \text{ msec (Start)} + 1,000 \text{ msec} \times (\text{Measurement}_{(\text{ppm})} / \text{Range}_{(\text{ppm})}), T_L = 2,000 \text{ ms} - t_H,$$

Pin Map with J13 Connectors

J-13	S-300-3V	S-300-3V (PWM or AVO Option)
1	Reserved	Analog Voltage Output (Option)
2	Alarm (Open Collector)	
3	GND	
4	VDD (+3.3V VCC)	
5	TTL TXD (→ CPU of Master Board)	
6	TTL RXD (← CPU of Master Board)	
7	Reserved	PWM Output (Option)
8	I2C SCL	
9	I2C SDA	
10	Reset (Low Active)	
11	ACDL(Automatic Calibration)	
12	Reserved	
13	MCDL(10 min. Manual Calibration)	

Dimensions unit : mm

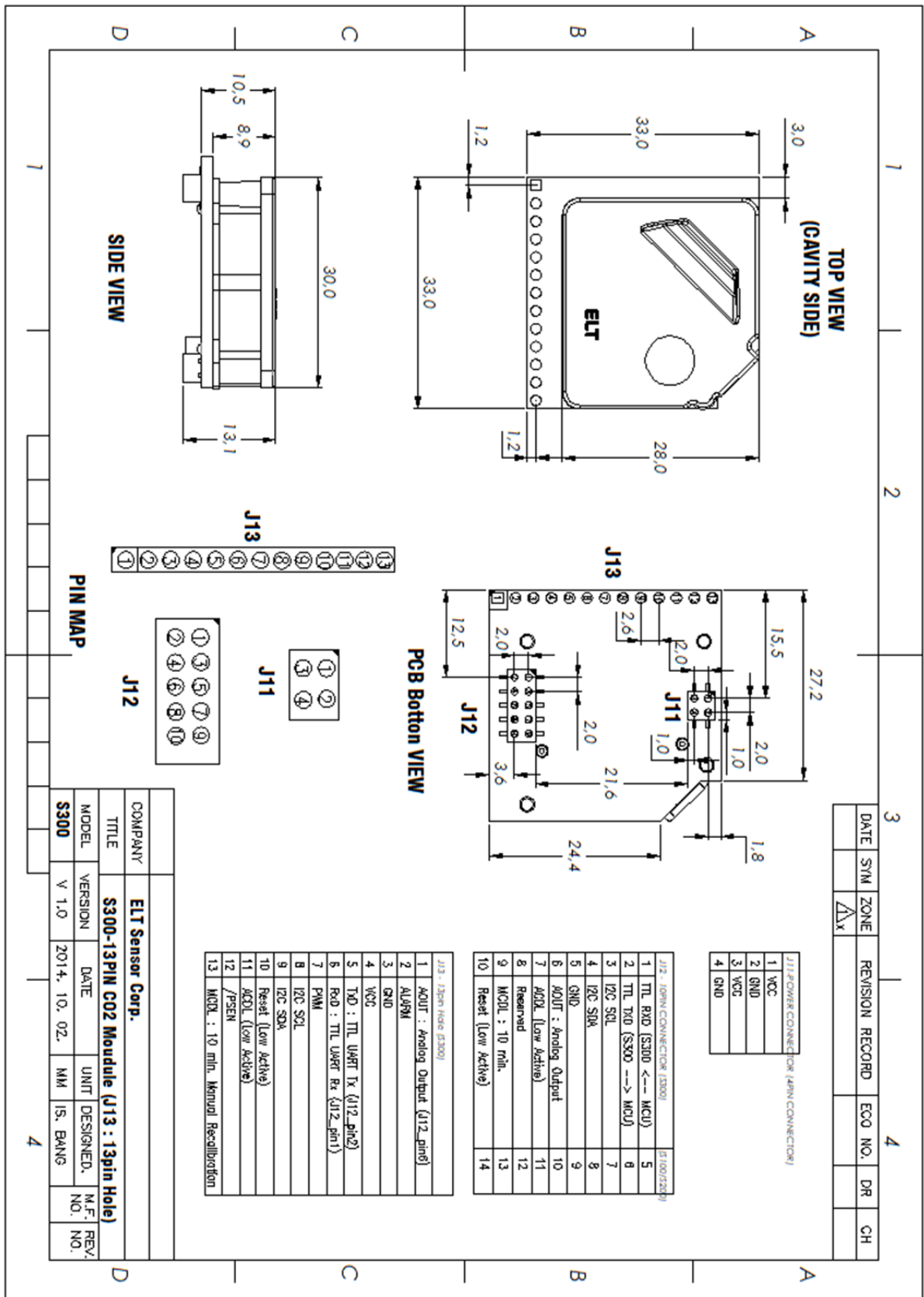

ACDL function (Automatic Calibration Function in Dimming light with period)

ACDL could be activated as by setting below.

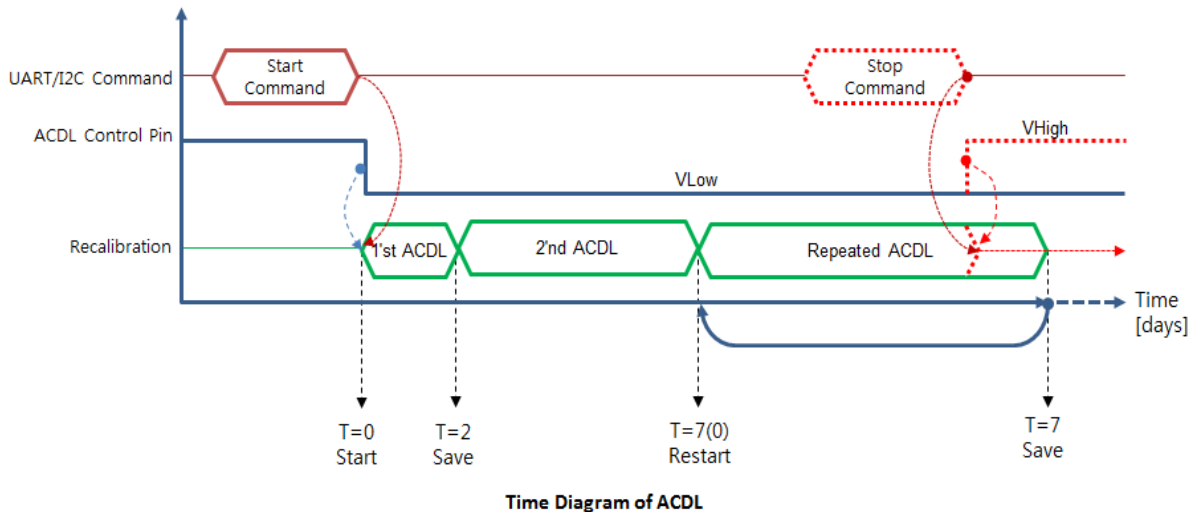

Method 1. For Digital output (U-ART or I2C), Command Sets for ACDL is available.

UART Command Set ; J12: pin-1 (UART-RX) and pin-2 (UART-TX) to Main-Board.

(J13: pin-6 and pin-5 are available as well)

I2C Command Set; J12: pin-3 (SCL) and pin-4 (SDA) to Main-Board.

(J13: pin-8 and pin-9 are available as well)

Method 2. For PWM or AVO (Analog Voltage Output), Hardware based ACDL setting is available.

J12:pin-7 or J13:pin-11	J12:pin-9 or J13:pin-13	Status	Notes
Low	High	H/W ACDL	Calibrate weekly after 2 days since power-on
High	High	Normal	Operate with Pre-calibrated value in Factory or previous state.

※ 1. (J12:pin-7 or J13:pin-11) and (J12:pin-9 or J13:pin-13) shouldn't have 'Low' at any time.

Cf.) Unlike other S-300-3V series, S-300A-3V operate with software based ACDL setting, which make sensor always operate with ACDL as default unless MCDL is activated.

Method 3. Let Sensor install on Jig Board, **TRB-100ST (Test and Recalibration Board)** with ambient air-flow condition and execute by moving jumper following Manual on the website.

Method 4. **EK-100SL (Evaluation kit, with Emulation program 'ELTWSO')** is available, which display and save data on PC through USB connection.

10' MCDL function (10 minute Manual Calibration Function in Dimming light).

MCDL enable customer to calibrate as needed, MCDL keep at least 10 minute once it start and should be stopped before 18minute to avoid MCDL fetch repetition.

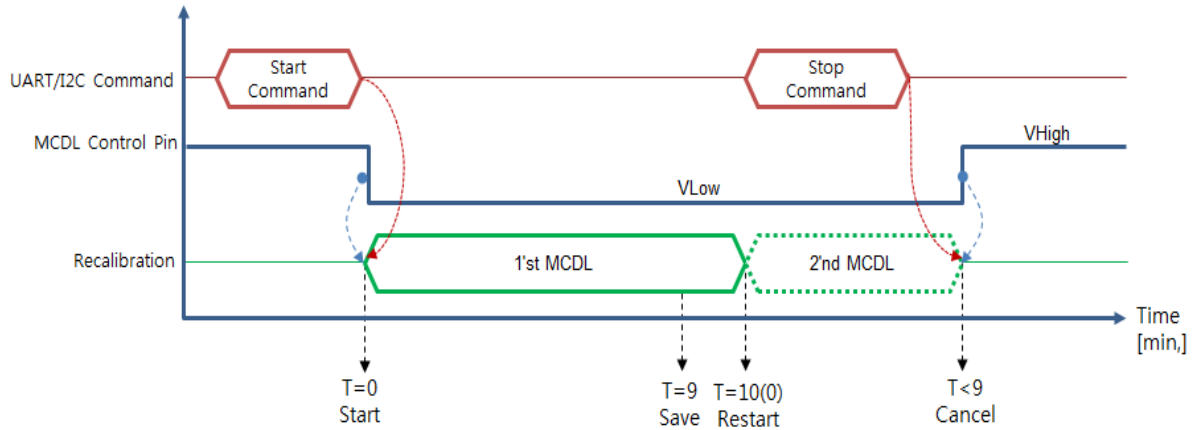

Time Diagram of MCDL

Method 1. For Digital output (U-ART or I2C), Command Sets for ACDL is available.

UART Command Set ; J12: pin-1 (UART-RX) and pin-2 (UART-TX) to Main-Board.

(J13: pin-6 and pin-5 are available as well)

I2C Command Set; J12: pin-3 (SCL) and pin-4 (SDA) to Main-Board.

(J13: pin-8 and pin-9 are available as well)

Method 2. For PWM or AVO (Analog Voltage Output), Hardware based MCDL setting is available.

J12:pin-7 or J13:pin-11	J12:pin-9 or J13:pin-13	Status	Notes
High	Low	H/W MCDL	sensor should be located in 400ppm environment (outside) for 10 minutes
High	High	Normal	Operate with Pre-calibrated value in Factory or previous state.

- ※ 1. (J12:pin-7 or J13:pin-11) and (J12:pin-9 or J13:pin-13) shouldn't have 'Low' at any time.
- 2. Be sure to quit MCDL fetch loop before 18minute.

cf.) Unlike other S-300-3V series, S-300A-3V has nothing to do with (J12:pin-7 or J13:pin-11). It is designed to execute MCDL during pin-13 get Low Active Signal. it return to ACDL as the signal to pin-13 is changed to High De-Active Signal.

Method 3. Let Sensor install on Jig Board, **TRB-100ST (Test and Recalibration Board)** with ambient air-flow condition and execute by moving jumper following Manual on the website.

Method 4. **EK-100SL (Evaluation kit, with Emulation program 'ELTWSD')** is available, which display and save data on PC through USB connection.

*** Set present CO2 value with Target PPM function**

1. Deviated CO2 sensors can be adjusted with target PPM function via I2C or UART interface.
(Refer to '**I2C Programming guide**' or '**UART Command guide**')

2. EK-100SL (Evaluation kit, with Emulation program 'ELTWSD') is available for Target PPM function.
(Refer to '**EK-100SL manual**')

Output Descriptions

UART Descriptions

Data Transmit

Interval : 3 seconds

Handshake protocol : None (Data is transmitted to outer device periodically)

Data Format

D6	D5	D4	D3	D2	D1	SP	'p'	'p'	'm'	CR	LF
D6 ~ D1						6 byte CO2 density string					
SP						Space: 0x20					
'ppm'						'ppm' string					
CR						Carriage return : 0x0D					
LF						Line feed : 0x0A					

Above 12byte consist by 6 byte hexadecimal digits, <SP>, 0x70 0x70 0x6D, <CR> <LF> , where decimal '0' (corresponds to hexadecimal digit '0x30') is replaced by space (corresponds to hexadecimal digit '0x20'),

EX) 1,255 ppm, results '0x20 0x20 0x31 0x32 0x35 0x35 0x20 0x70 0x70 0x6D 0x0D 0x0A', which displays '_1255_ppm<CR><LF>' on screen.

I2C Communication (Only Slave Mode Operation)

Internal pull up resistor

Slave Address: 0x31, Slave Address Byte: Slave Address(0x31) 7 Bit + R/W 1 Bit

Bit7	Bit6	Bit5	Bit4	Bit3	Bit2	Bit1	Bit0
0	1	1	0	0	0	1	R/W Bit

R/W Bit : Read = 1/Write = 0

When reading the data, Slave Address Byte is 0x63, When writing the data, Slave Address Byte is 0x62.

Block Diagram

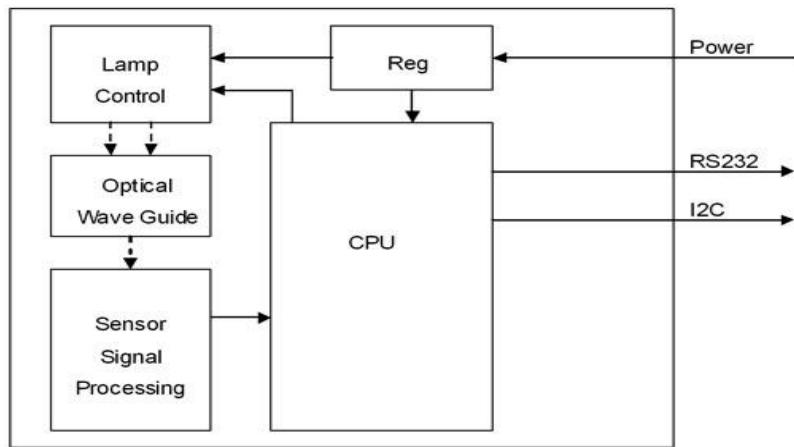

Transmission Sequence in Master

- 1) I2C Start Condition
- 2) Write Command(Slave Address + R/W Bit(0) = 0x62) Transmission and Check Acknowledge
- 3) Write Command(ASCII 'R' : 0x52) Transmission and Check Acknowledge
- 4) I2C Stop Command
- 5) I2C Start Command
- 6) Read Command(Slave Address + R/W Bit(1) = 0x63) Transmission and Check Acknowledge
- 7) Read 7 Byte Receiving Data from Module and Send Acknowledge
(Delay at least 1ms for reading each byte)

Configuration	CO ₂	reserved	reserved	reserved	reserved
1 Byte	2 Byte	0x00	0x00	0x00	0x00

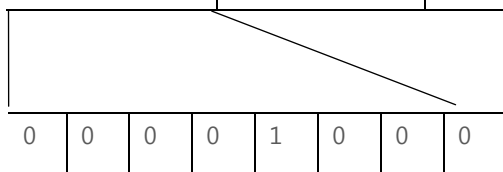

In need of detail protocol specification and time sequence, I2C programming guide is providable by contacting Sales Rep.

Alarm Descriptions

Alarm is Open Collector type which work SPST (Single Pole Single Throw). Alarm is 'OFF' status at first and turn to 'ON' status since CO2 value go beyond 1,000ppm until it go down to 800ppm to avoid unwanted rapid switching by hysteresis effect.

1,000 ppm ≤ Alarm ON, 800 ppm ≥ Alarm OFF

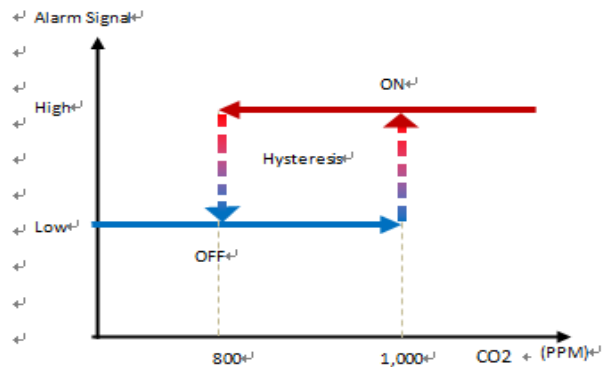

2nd Alarm use 0.5V/3V TTL signal Switching instead of SPST (Single Pole Single Throw) method.

EK-100SL series is available for customer to enable to change alarm activation & deactivation point.

PWM Descriptions ; Option

* Measurement_(ppm) = (t_H-2msec)/1000msec x Range_(ppm) (t_H : High Pulse Width)

* Range_(ppm) : 2,000/3,000/5,000/10,000 ppm (20,000/30,000/50,000/100,000 is optional.)

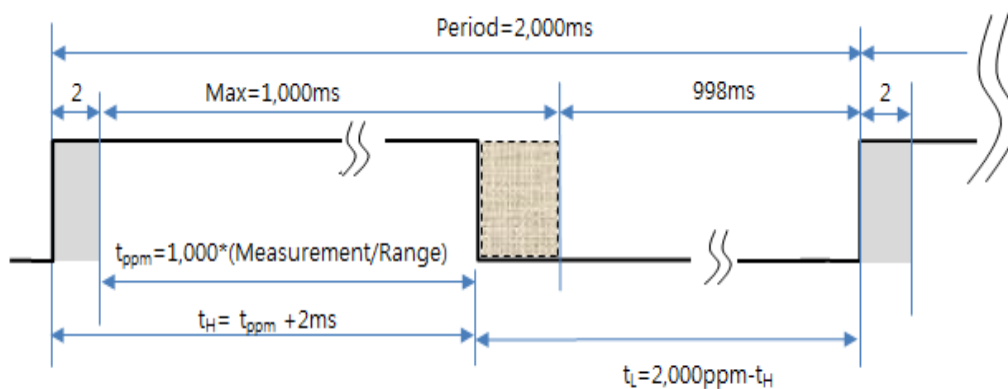

EX) t_H (High Pulse Width) calculation for 400 ppm in 2,000 ppm Range.

*Measurement_(ppm) = 400 ppm = (t_H-2msec)/2,000msec x Range_(ppm) ,

*t_H = 1,000 msec * (400 ppm / 2,000 ppm) + 2msec = 202msec

(cf: T_L = Period - t_H = 2,000 ppm - 202 msec = 1,798 msec.)

AVO Description ; Option

* Measurement_(ppm) : 0.5~3.0V

Measured Voltage 0.5V~3.0V matches proportionally to 0 ~ 2,000/3,000/5,000/10,000 ppm
or 2%/3%/5%. ppm

* CO2 Measurement_(ppm) = ((Output Voltage - 0.5) / (3.0 - 0.5) Voltage) x F.S. ppm ,
cf. F.S. (ppm) : 2,000/3,000/5,000/10,000 ppm (20,000/30,000/50,000/100,000 is optional.)

EX) if the Output Voltage is 2.5V in 2,000 ppm (F.S. of Reading range)

$$\begin{aligned} \text{CO2 Measurement}_{\text{ppm}} &= (2.5 - 0.5) \text{ V} \div (3.0 - 0.5) \text{ V} \times 2,000. \text{ ppm} \\ &= 2 \div 2.5 \times 2,000 \text{ ppm} = 1,600 \text{ ppm} \end{aligned}$$

※ Caution

1. Please hold only 'PCB' of sensor without holding Cavity directly to avoid the physical shock on sensor. Rough handling or Transportation could result in inaccurate reading.
2. Proper ESD protection during handling is important to avoid electrostatic defect occurrence. The storage of sensor should be insulated as well.